

Patent 6253416 and other patents pending
BILLY GOAT POWER RAKE AND OVERSEEDER
 PR550, PR550H, OS552, OS552H
Owner's Manual

Accessories

SLICING REEL	SLICING BLADES
A complete verti-slicing reel for your PR. 20" wide reel for use in grasses that require vertical cutting, and for assisting in lawn overseeding projects.	A full set of blades for replacement. Includes new lock washers for replacement installation.
P/N 350414	P/N 350187

OVERSEEDER KIT
The new light weight Plastic Overseeding Kit is constructed of durable High Density Polypropylene with two lift handles on each side to assist in lifting the entire unit and easily converts a PR Series Power Rake into an overseeder with 4 bolts and minimal tools. NOTE: Overseeder Conversion Kit (350328) includes Slicing Reel (350113). Part No. (350325) comes with the Overseeder Box only.
P/N 350325 / 350328

Replacement Parts

FLAIL BLADES	FLAIL SHAFTS
A complete set of our high quality flail blades for your PR. Includes new lock clips for replacement installation.	A full set of shafts for replacement. Includes new lock clips for replacement installation.
P/N 350186	P/N 350185



CONTENTS

SPECIFICATIONS AND SOUND/VIBRATION	3
INSTRUCTION LABELS	4
PACKING CHECKLIST & ASSEMBLY	5
OPERATION	6-8
MAINTENANCE	9
TROUBLESHOOTING	10
ILLUSTRATED PARTS LIST	11-16



Specifications

	PR550	PR550H	OS552	OS552H
Engine: HP	5.5 (4.1 kW)	5.5 (4.1 kW)	5.5 (4.1 kW)	5.5 (4.1 kW)
Engine: Model	12H1320118B8	GX160T1QX2	12H1320118B8	GX160T1QX2
Engine: Type	B&S VANGUARD	HONDA OHV	B&S VANGUARD	HONDA OHV
Engine: Fuel Capacity	3.0 qt. (2.84 L)	3.88 qt. (3.6 L)	3.0 qt. (2.84 L)	3.88 qt. (3.6 L)
Engine: Oil Capacity	0.66 qt. (0.62 L)	0.69 qt. (0.65 L)	0.66 qt. (0.62 L)	0.69 qt. (0.65 L)
Total Unit Weight:	149# (67.7 kg)	147# (66.8 kg)	162# (73.6 kg)	160# (72.7 kg)
Engine weight:	36# (16.3 kg)	34# (15.4 kg)	36# (16.3 kg)	34# (15.4 kg)
Max. operating slope	15°	20°	15°	15°
Sound test in accordance with 2000/14/EC	101 dB(a)	101 dB(a)	101 dB(a)	101 dB(a)
Sound at operators ear	82 dB(a)	82 dB(a)	82 dB(a)	82 dB(a)
Vibration at operator position	0.82g (8.04 m/s ²)	0.82g (8.04 m/s ²)	3.2g	3.2g

SOUND



SOUND LEVEL 82 dB(a) at Operators Position

Sound tests were conducted in accordance with 2000/14/EC, and were performed on 2-13-2002 under the conditions listed below.

⚠ Sound power level listed is the highest value for any model covered in this manual. Please refer to serial plate on the unit for the sound power level for your model.

General Conditions:	Sunny
Temperature:	48°F (8.9°C)
Wind Speed:	2 mph (3.2 kmh)
Wind Direction:	South East
Humidity:	29%
Barometric Pressure:	30.34Hg (770 mm Hg)

VIBRATION DATA

VIBRATION LEVEL .82g (8.04m/s²)

Vibration levels at the operator's handles were measured in the vertical, lateral and longitudinal directions using calibrated vibration test equipment. Tests were performed on 5-25-2006 under the conditions listed below.

General Conditions:	Sunny
Temperature:	72.32°F (22.4°C)
Wind Speed:	3.8 mph (6.12kph)
Wind Direction:	East
Humidity:	62.2%
Barometric Pressure:	29.9Hg (101.3kpa)



PACKING CHECKLIST

Your Billy Goat Power Rake is shipped from the factory in one carton, completely assembled.



READ all safety instructions before assembling unit.

TAKE CAUTION when removing the unit from the box the Handle Assembly is attached to the unit by cables.



PUT OIL IN ENGINE BEFORE STARTING

PARTS BAG & LITERATURE ASSY

Warranty card P/N- 400972, Owner's Manual P/N-350412, General Safety and Warnings Manual P/N-100295. Declaration of Conformity P/N-350139.

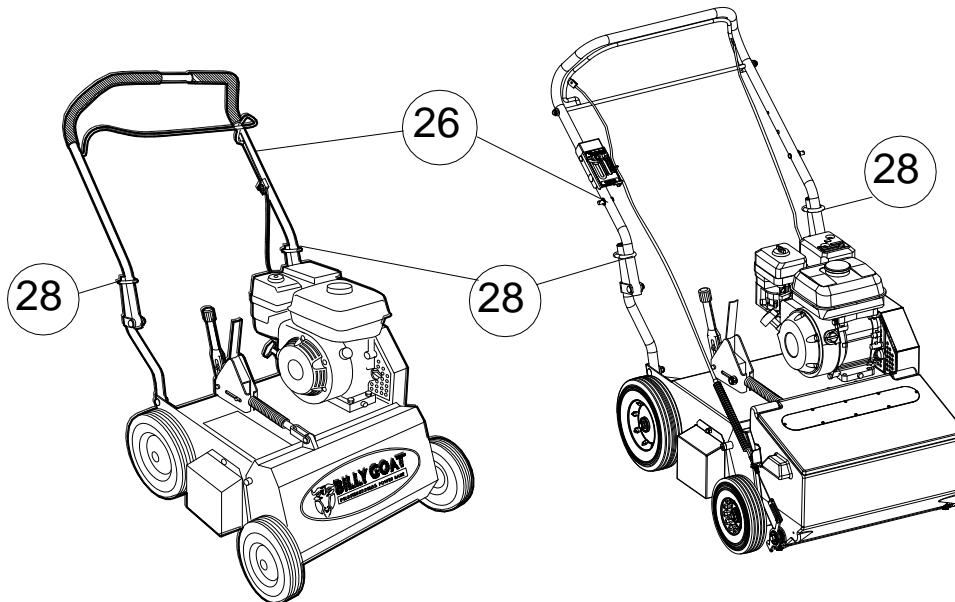

PR550, PR550H,
PR550T, PR550HT,
PR600S

OS552, OS552H,
and OS602S

Boxing Parts Checklist

- Briggs & Stratton 5.5 B&S VANGUARD
- Honda 5.5 OHV
- Subaru 6HP EX17
- Literature Assy P/N-350110

ASSEMBLY

1. **UNFOLD** the upper handle (item 26) and slide handle lock loops (item 28) into place to secure the upper handle to the lower.
2. **CHECK** engine oil level and fill to proper level with engine manufacturers recommended grade of oil. Move height adjust lever to down position, to level engine during checking. See engine manufacturer's instruction manual.
3. **CONNECT** spark plug wire.



OPERATION

FOLDING HANDLE

This unit is equipped with a folding upper handle for easier storage and transportation. The handle can be folded by sliding the handle lock loops (item 28) up. This releases the upper handle, allowing it to be folded over the unit.

ADJUSTING BLADE DEPTH

The depth of the blades can be raised or lowered by rotating the knob on the top of the adjustment lever. The blades are lowered by rotating the knob clockwise, and raised by rotating the knob counter-clockwise. The relative depth of the blades can be gauged by using the depth scale located on the right front corner of the engine base. With new blades installed the depth can be estimated as follows: 2.5 on the scale is even with the ground, 3 is equal to 0.25" deep, and 3.5 is equal to 0.5" deep

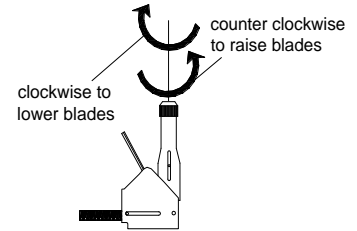

BLADE POSITION & DEPTH CONTROL LEVER

The blades can be raised or lowered into the ground by height adjustment lever on the engine base. The height adjuster lock lever must be pushed back against the adjustment lever in order to lower the blades into the ground. The resulting blade depth can be adjusted higher or lower. See ADJUSTING BLADE DEPTH.

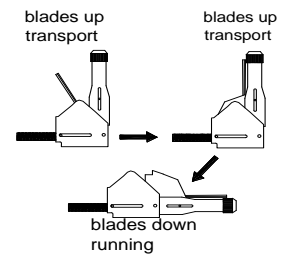

SPRING TINE CONVERSION

If are converting your Power rake to a spring tine reel, you will need to replace the spacer on the control lever to accommodate for the tine. First remove the clip (item 18), then unscrew the yoke (item 17), remove the washer (items 69) and insert the spacer (item 75) in front of the spring. Reassemble in reverse order.

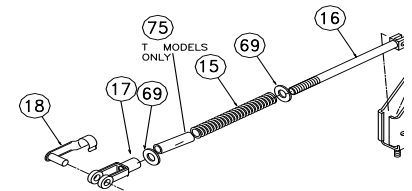

RAKING/SLICING TIPS

Before beginning, it is best to evaluate the condition of the lawn by cutting one or more core samples from area to be treated. A core can be cut using a piece of PVC, or metal pipe. Hammer the pipe into the ground, remove it, push the core out of the pipe and inspect it to determine the depth of thatch in your yard.

THATCH: Thatch is a dense layer of dead grass, clippings, and roots that builds up over time at the base of the lawn preventing air, water, and fertilizer from reaching the soil. This can cause shallow root development and make a lawn more susceptible to drought and disease. Thatch also provides an ideal environment for insects to hide and multiply. Periodic removal of thatch will keep your lawn in good health.

HEAVY THATCH: Lawns with an excessive amount of thatch will require multiple treatments for effective removal. Trying to remove excessive thatch (greater than 3/4"[19 mm] deep) in one treatment will damage or destroy the living part of the lawn. It is best to remove heavy thatch in seasonal treatments (i.e. spring, and fall).

SLOPES: Rake slopes across not up and down. This is much easier and safer for the operator and is better for the lawn. Raking across will help to reduce runoff during watering and allow the sloped ground to hold more seed, fertilizer, and water. The unit's maximum operating slope is 35% or 19°.

DEPTH: The wide range of depth adjustment on your unit is provided to allow for blade wear. Setting the reel deeper will not produce better or quicker results. The flail reel is intended to be set so it just touches the surface on flat ground. The slicing reel should be set even with the ground for verti-slicing work, and set to a maximum 1/2" depth for overseeding jobs. Setting the reel deeper than this will only result in premature wear on the unit (i.e. failed belt). If you desire to work the ground deeper than the above guidelines allow, it should be done gradually in multiple passes.

SLICING / OVERSEEDING: Mow the lawn to shorter than the normal cut height before starting (i.e. approximately 2" tall for fescue grass). For the best result, Slice/Overseed in criss-cross pattern (See Fig. 1 and See Fig 2).

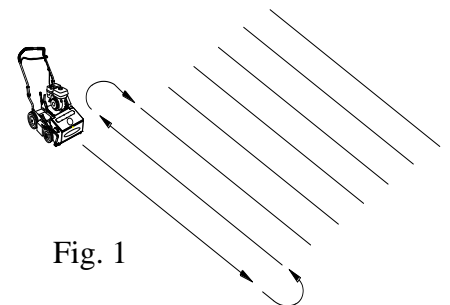

Fig. 1

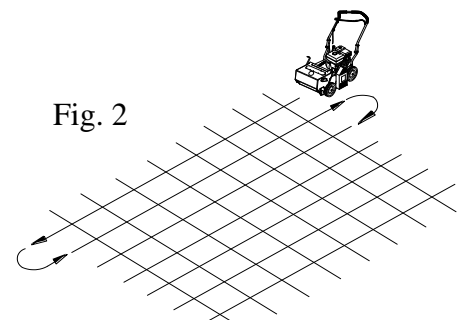

Fig. 2



RAKING OPERATION-FLAIL REEL

NOTE: Must have the flail reel assembly (350112) for this operation.

MOW: Mow the lawn to it's normal cut height.

DRY: Be sure grass is dry. Wet conditions can cause increased damage to healthy grass.

SET DEPTH: With engine off, set the raking depth so that the blades just touch on a flat surface (i.e. driveway, or sidewalk).

START ENGINE: See General Safety and operation manual.

ENGAGE BLADES: Pull back on the bail on the operators handle. **NOTE:** When engaging the blades in heavy load conditions (i.e. heavy thatch, or very uneven turf), push down on the operators handle lifting the front wheels slightly. Engage the blades. Slowly lower the unit into the turf.

RAKE: Rake a small test area and examine the results. Thatch should be removed and deposited on top of the healthy grass. If excessive damage occurs to healthy grass, adjust the blade depth to decrease damage. Continue raking the yard, working in one direction (i.e. north-south, or east-west). **NOTE:** If a large drop in engine RPM occurs, or the unit pulls you forward and bounces during operation the blade depth is set too low.

REMOVE THATCH: After raking, a layer of thatch will be deposited over the top of the lawn. This thatch must be removed prior to any fertilizing, seeding, or watering of the lawn. We suggest the use of a lawn vacuum or wheeled blower for collection and removal of the thatch.

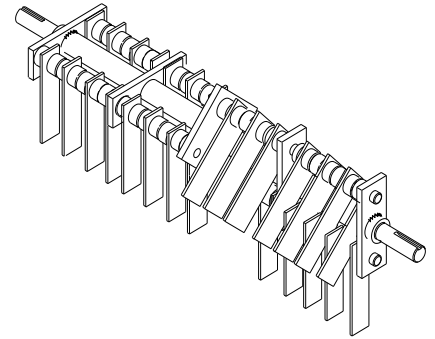

RAKING OPERATION-SPRING REEL

NOTE: Must have the spring tine reel assembly (350354) for this operation.

MOW: Mow the lawn to it's normal cut height. Tall grass will not leave a manicured look when the dethatching job is complete.

DRY: Be sure grass is relatively dry. Wet conditions can cause increased damage to healthy grass.

SET DEPTH: With engine off, set the raking depth so that the spring tines are just above touching the flat surface (i.e. driveway, or sidewalk) the units height is being adjusted on. **NOTE:** Allowing the spring tines to have substantial contact with the ground will cause premature wear and failure of the spring tines.

START ENGINE: See General Safety and operation manual.

ENGAGE TINES: Pull back on the bail on the operators handle. **NOTE:** When engaging the spring tines in heavy load conditions (i.e. heavy thatch, or very uneven turf), push down on the operators handle lifting the front wheels slightly. Engage the spring tines. Slowly lower the unit into the turf.

RAKE: Rake a small test area and examine the results. Thatch should be removed and deposited on top of the healthy grass. If excessive damage occurs to healthy grass, adjust the spring tine depth to decrease damage. Continue raking the yard, working in one direction (i.e. north-south, or east-west).

NOTE: If a large drop in engine RPM occurs, or the unit pulls you forward and bounces during operation the spring tine depth is set too low.

REMOVE THATCH: After raking, a layer of thatch will be deposited over the top of the lawn. This thatch must be removed prior to any fertilizing, seeding, or watering of the lawn. We suggest the use of a lawn vacuum or wheeled blower for collection and removal of the thatch.

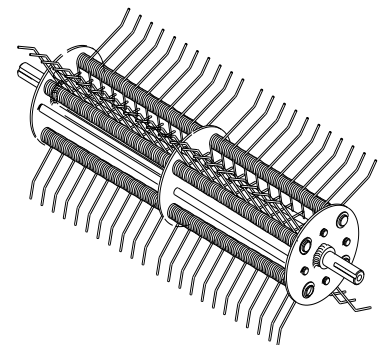

VERTI-CUTTING OPERATION

NOTE: Must have the slicing reel assembly (350113) for this operation.

MOW: Mow the lawn to shorter than the normal cut height (approximately 2" tall)

DRY: Be sure grass is dry. Wet conditions can cause increased damage to healthy grass.

SET DEPTH: With engine off, set the raking depth so that the blades just touch on a flat surface (i.e. driveway, or sidewalk).

START ENGINE: See General Safety and operation manual.

ENGAGE BLADES: Pull back on the bail on the operators handle. **NOTE:** When engaging the blades in heavy load conditions (i.e. heavy thatch, or very uneven turf), push down on the operators handle lifting the front wheels slightly. Engage the blades. Slowly lower the unit into the turf.

SLICE: Verti-cut a small test area and examine the results. Some thatch and cut stems should be removed and deposited on top of the healthy grass. Grass runners should be cut and ready for removal. If excessive damage occurs to healthy grass, adjust the blade depth to decrease damage. Continue raking the yard, working in one direction (i.e. north-south, or east-west).

NOTE: If a large drop in engine RPM occurs, or the unit pulls you forward and bounces during operation the blade depth is set too low.

REMOVE THATCH/STEMS: After verti-cutting, a layer of thatch and cut stems will be deposited over the top of the lawn. We suggest the use of a lawn vacuum or wheeled blower for collection and removal of the thatch/stems.

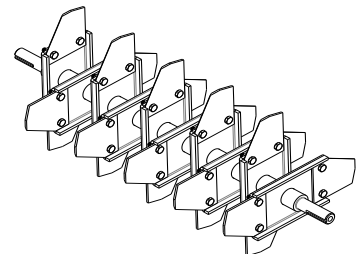



PR & OS Owner's Manual

OVERSEEDING OPERATION

NOTE: Must have the slicing reel assembly (350113) for this operation.

MOW: Mow the lawn to shorter than the normal cut height (approximately 2" tall)

DRY: Be sure grass is dry. Wet conditions can cause increased damage to healthy grass.

SEED: Spread grass seed according to the seed suppliers directions (e.g. 10 lbs. per 1000 ft² [4.5 kg. per 93 m²])

SET DEPTH: With engine off, set the raking depth so that the blades reach 1/4"-1/2" (6-12 mm) below a flat surface (i.e. driveway, or sidewalk).

START ENGINE: See General Safety and operation manual.

ENGAGE CLUTCH: Pull back on the bail on the operators handle. **NOTE:** When engaging the clutch in heavy load conditions (i.e. heavy thatch, or very uneven turf), push down on the operators handle lifting the front wheels slightly. Engage the clutch. Slowly lower the unit into the turf.

SLICE: Run machine over the area that has been seeded to incorporate the seed into the soil. If excessive damage occurs to healthy grass, adjust the blade depth to decrease damage. Continue raking the yard, working in one direction (i.e. north-south, or east-west). **NOTE:** If a large drop in engine RPM occurs, or the unit pulls you forward and bounces during operation the blade depth is set too low.

WATER/FERTILIZE: After the seed has been worked into the soil, water and fertilize according to the seed suppliers directions.

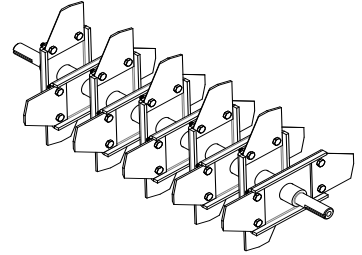

ADJUSTING SEED RATE

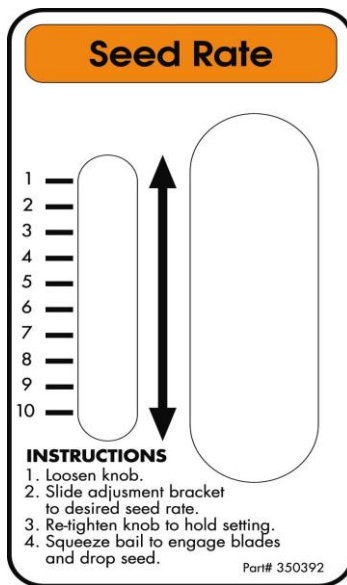

LAWN PREPARATION

- MOW LAWN TO LOWEST SETTING ON YOUR MOWER.
- DO NOT WATER PRIOR TO SEEDING.
- POWER RAKE TO DETHATCH LAWN AND REMOVE THATCH.
- FERTILIZE LAWN WITH BROADCAST SPREADER.

LAWN PREPARATION

- FOR BEST RESULTS OVERSEED IN TWO PASSES OF ONE-HALF APPLICATION RATE EACH, AT RIGHT ANGLES OR IN A CRISS-CROSS PATTERN.
- WATER HEAVILY IMMEDIATELY THEN LIGHTLY FOR 10 - 14 DAYS, KEEPING SOIL MOIST.
- AFTER GERMINATION, WATER LESS OFTEN TO PROMOTE ROOT GROWTH.

SEED APPLICATION CHART:

THE SETTINGS SHOWN ARE APPROXIMATE GUIDELINES. SEEDING RATES ARE SPEED DEPENDENT. FASTER TRAVEL DELIVERS LESS SEED, SLOWER TRAVEL DELIVERS MORE SEED.

SEED TYPE	RATE LBS 1,000 FT ₂	STOP SETTING	SEED TYPE	RATE LBS 1,000 FT ₂	STOP SETTING
RYE GRASS	1/2	2	BENT GRASS	2/3	2
	3/4	3		1 1/3	3
	1 1/2	4	BERMUDAGRASS (HULLED & ZOYSIA)	3/4	2
	2 1/3	5		1 2/3	3
BLUE GRASS	3/4	4	CENTIPEDE GRASS (COATED)	2/3	2
	1	5		1 1/4	3
	1 1/2	6		2 1/2	4
FESCUE	2 1/2	7	ST. AUGUSTINE GRASS	3/4	4
	3/4	6		1	5
	1 1/4	7		1 1/3	6
	2	8		1 1/2	7
	3 1/2	9			

MAINTENANCE

PERIODIC MAINTENANCE

Periodic maintenance should be performed at the following intervals:

Maintenance Operation	Every Use (daily)	Every 25 Hours
Inspect for loose, worn or damaged parts.		●
Check engine oil	●	
Inspect belt		●
Engine (See Engine Manual)		
Grease reel bearings		●
Inspect and clean engine air filter	●	
Oil height adjustment linkage		●

FLAIL BLADE WEAR

1. Wait for engine to cool and disconnect spark plug.
2. Close fuel valve on engine (if available).
3. Lean unit back onto lower handles and secure in place.
4. Inspect blades for wear, and immediately replace any bent or cracked blades. Measure the overall length of the blade. (See fig. 1)
5. If blades measure less than 3.25"(83 mm) in overall length they must be replaced. NOTE: We recommend replacing all the flails at once.

SLICING BLADE WEAR

1. Wait for engine to cool and disconnect spark plug.
2. Close fuel valve on engine (if available).
3. Lean unit back onto lower handles and secure in place.
4. Inspect blades for wear, and immediately replace any bent or cracked blades. Measure the overall length of the blade from the center of the attachment bolt to the tip of the worn blade.
5. If blades measure less than 3"(76 mm) in length they must be replaced. NOTE: We recommend replacing all the blades at once.

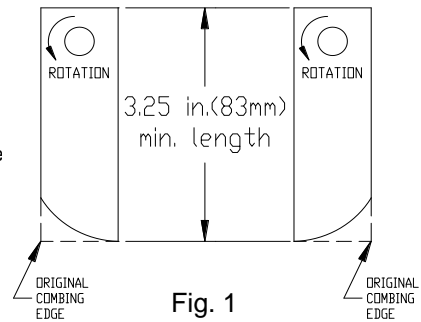

Fig. 1

ROTATING FLAIL REEL END TO END

To maximize flail blade life and performance the reel can be rotated end to end periodically to provide a fresh lead cutting edge. Takes approx. 20 min. and requires 1/2" and 9/16" socket wrenches with extension bar.

1. Wait for engine to cool and disconnect spark plug.
2. Close fuel valve on engine (if available).
3. Lean unit back onto lower handles and secure in place.
4. Remove (7) lock nuts (item 62 & 40) holding the belt and shaft guards (item 21 & 22) in place. It is necessary to lower the height adjust lever to reach the locknuts on the guards. Remove the guards.
5. Remove the drive belt (item 9) by "walking" it out of the groove on the reel pulley (item 2).
6. Remove the (4) lock nuts (item 60) and washers (item 68) holding the bearings (item 23) to the frame of the unit.
7. The reel is now free from the machine. Slide the reel down and out of the machine.
8. Remove the capscrew (item 71), lock washer (item 57), reel pulley (item 2), key (item 42), and reel spacer (item 10) from the end of the reel.
9. Rotate the reel end to end, and re-install these items on the opposite end of the reel.
10. Re-install the reel in reverse order of removal. Re-install the guards in reverse order of removal.

DRIVE BELT REPLACEMENT

NOTE: Takes approx. 10 min. and requires 1/2" socket wrench with extension.

1. Wait for engine to cool and disconnect spark plug.
2. Remove (4) lock nuts (item 62) holding the belt guard (item 21) in place. It is necessary to lower the height adjust lever to reach the locknuts on the guard. Remove the guard.
3. Remove the belt (item 9) by rotating the reel pulley (item 2) and walking it out of the groove. Discard the old belt.
4. Install new belt using same procedure to walk the belt into the groove.
5. With new belt installed pull bail rod back to engaged position and measure extension of idler spring. Spring should stretch 3/4" - 1" (19 25 mm) with bail engaged. Adjust clutch cable as necessary to achieve this extension.
6. Re-install the belt guard.



PR & OS Owner's Manual

Troubleshooting

Problem	Possible Cause	Solution
Abnormal vibration.	<ul style="list-style-type: none"> · Damaged or missing blades. Loose handle bolts. Loose engine bolts 	<ul style="list-style-type: none"> · Stop work immediately. Replace any damaged or missing blades. Tighten all loose nuts and bolts.
Engine stalls or labors when raking	<ul style="list-style-type: none"> · Blades set too deep into ground. 	<ul style="list-style-type: none"> · Raise blades so that they just touch the ground on a level surface
Engine will not start.	<ul style="list-style-type: none"> · Stop switch off (Honda only). Throttle in off position · Out of gasoline or bad, old gasoline. · Spark Plug wire disconnected. · Gas valve off. · Dirty air cleaner. 	<ul style="list-style-type: none"> · Check choke position. · Check gasoline. · Connect spark plug wire. · Turn on gas valve. · Clean or replace air cleaner. Contact a qualified service person.
Engine is locked, will not pull over.	<ul style="list-style-type: none"> · Debris locked against reel, or drive pulleys. Engine problem. 	<ul style="list-style-type: none"> · Pull spark plug wire and remove debris. Contact an engine servicing dealer for engine problems.

POWER RAKE SEEDER BOX KIT

P/N 350395

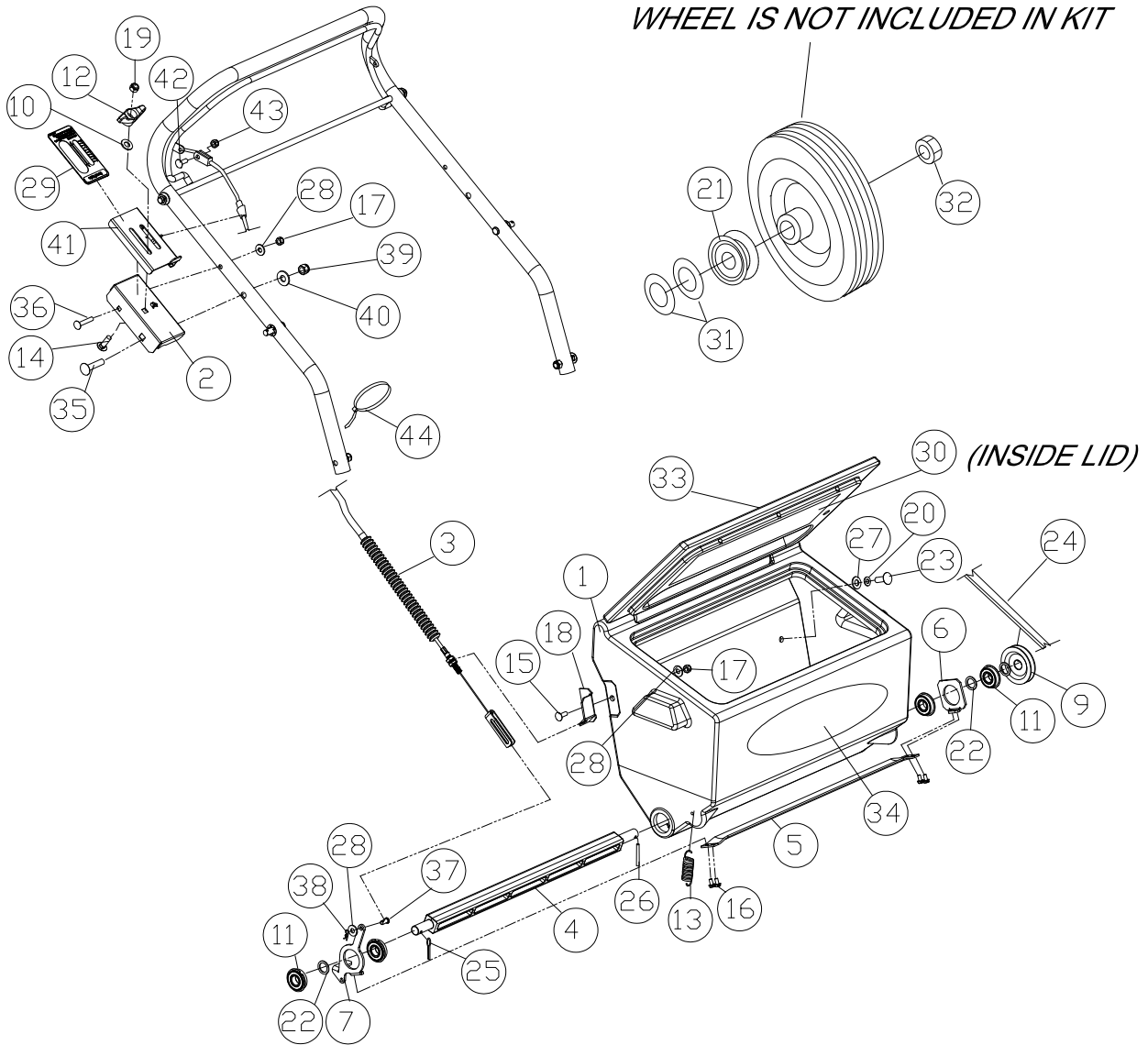

PARTS LIST			
ITEM NO.	PART NO.	DESCRIPTION	QTY
1	350366	BOX AND LID ASSEMBLY	1
2	350390	BRACKET CABLE MOUNTING	1
3	350385	CABLE SEED METERING ASSY	1
4	350378	SHAFT PLASTIC DROP SEEDER	1
5	350271	PLATE DOOR DROP SEEDER	1
6	350272	PLATE DOOR DROP SEEDER END	1
7	350387	PLATE DOOR DROP SEEDER END ARM	1
9	350370	PULLEY 3V GROOVE 0.625" BORE	1
10	8172009	WASHER #10 3/8 SAE	1
11	900321	BEARING CLIP 1.375 OD	4
	890108	KNOB WING 5/16-18	1
13	400217	SPRING TENSION	2
14	8024040	BOLT CARRIAGE 5/16 - 18 X 1	1
15	8024021	BOLT CARRIAGE 1/4-20 X 3/4"	1
16	8123087	SCREW SELF TAP #10-24 X 3/8" HMS ZP	4
17	8160001	NUT LOCK 1/4	1
18	350389	BRACKET CABLE SEEDER BOX	1
19	8160002	NUT LOCK 5/16	1
20	8177011	WASHER LOCK 5/16	4
21	350369	PULLEY 3V GROOVE 1.530" BORE	1
22	350280	WASHER 0.906 O.D. X 0.656 I.D. X 0.062	7-8

ITEM NO.	PART NO.	DESCRIPTION	QTY
23	8041026	SCREWCAP 5/16-18 x 3/4	4
24	350372	BELT O-RING 5/16 X 15 9/16"	1
25	8197031	PIN COTTER 1/8" X 1"	1
26	9195106	ROLL PIN 1/8 - 1 1/4	1
27	8172020	WASHER 5/16 FENDER	4
28	8172007	WASHER 1/4 SAE	3
29	350392	LABEL SEED METERING	1
30	350386	LABEL DROP SEEDER BOX	1
31	900230	WASHER 1/2 FC	2
32	8161044	NUT LOCK 1/2" THIN HGT	1
33	890456	LABEL HOSE PLUG KD/SV	1
34	350313	LABEL PRODUCT DECAL OS	1
35	8024061	CARRIAGE BOLT 3/8-16 X 1 3/4"	1
36	8024025	CARRIAGE BOLT 1/4-20 X 1 3/4"	1
37	350399	PIN CLEVIS .25 X .61	1
38	900471	PIN HAIR 1/4 ZP	1
39	8160003	NUT LOCK 3/8-16 HEX	1
40	8171004	WASHER 3/8 FC	2
41	350391	BRACKET MOUNTING METERING SEED	1
42	8059135	SCREW MACHINE #10-24 X 5/8	1
43	8164005	NUT LOCK LT #10-24 HEX	1
44	900407	TY-WRAP	1



PARTS DRAWING

FLAIL REEL KIT 350112

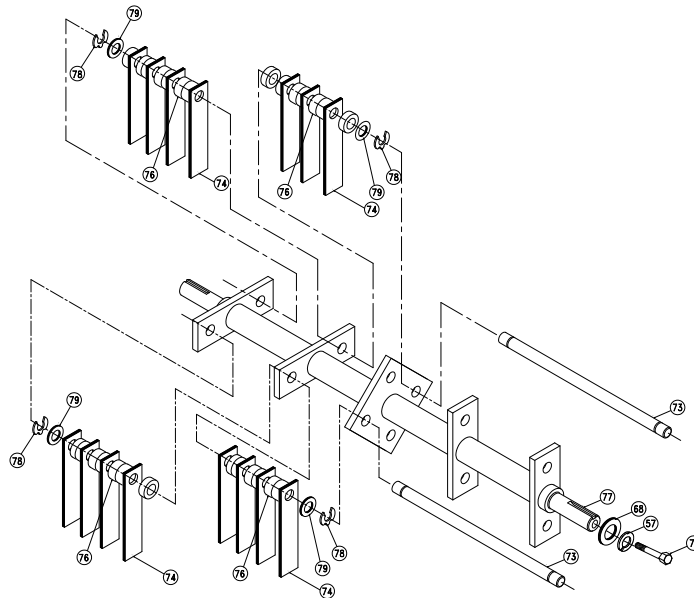

item no.	PARTS LIST	Part No.	QTY
57	LOCK WASHER 3/8 S/T MED	8177012	1
68	WASHER 3/8 FLAT CUT	8171004	1
71	SCREWCAP REEL PULLEY	8041050	1
73	SHAFT FLAIL BLADE	350141	4
74	BLADE FLAIL	350100	30
76	SPACER BUMPER 5/8" x 1/2"	350144	54
77	SHAFT WA FLAIL REEL	350145	1
78	CLIP LOCK 1/2"	350146	8
79	WASHER 1/2 SAE	8172011	8

FLAIL SHAFT KIT 350185

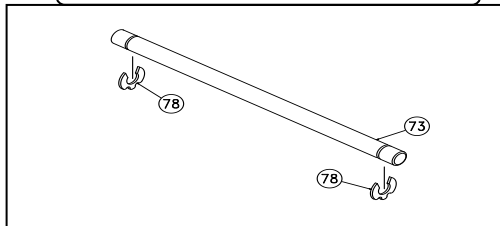

item no.	PARTS LIST	Part No.	QTY
73	SHAFT FLAIL BLADE	350141	4
78	CLIP LOCK 1/2"	350146	8

FLAIL BLADE KIT 350186

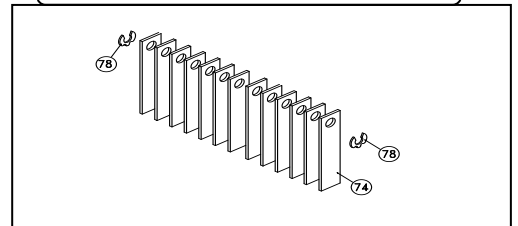

item no.	PARTS LIST	Part No.	QTY
74	BLADE FLAIL	350100	30
78	CLIP LOCK 1/2"	350146	8

SPACER BUMPER KIT 350258

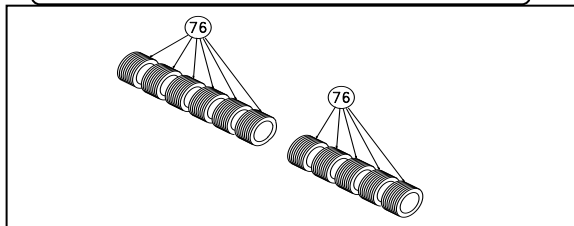

item no.	PARTS LIST	Part No.	QTY
76	SPACER BUMPER 5/8" x 1/2"	350144	54

SLICING BLADE KIT 350187

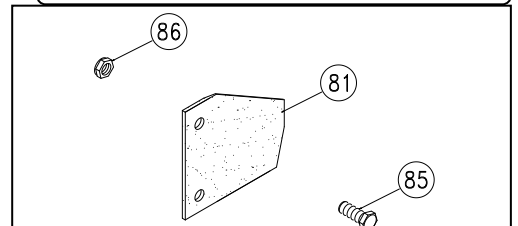

item no.	PARTS LIST	Part No.	QTY
81	BLADE 10" HEX SLICING	350147	20
85	SCREWCAP 1/4-20 X 3/4 HCS ZP	8041004	40
86	NUT LOCK 1/4-20	8142004	40

PARTS DRAWING

SLICING REEL ASSY 350113

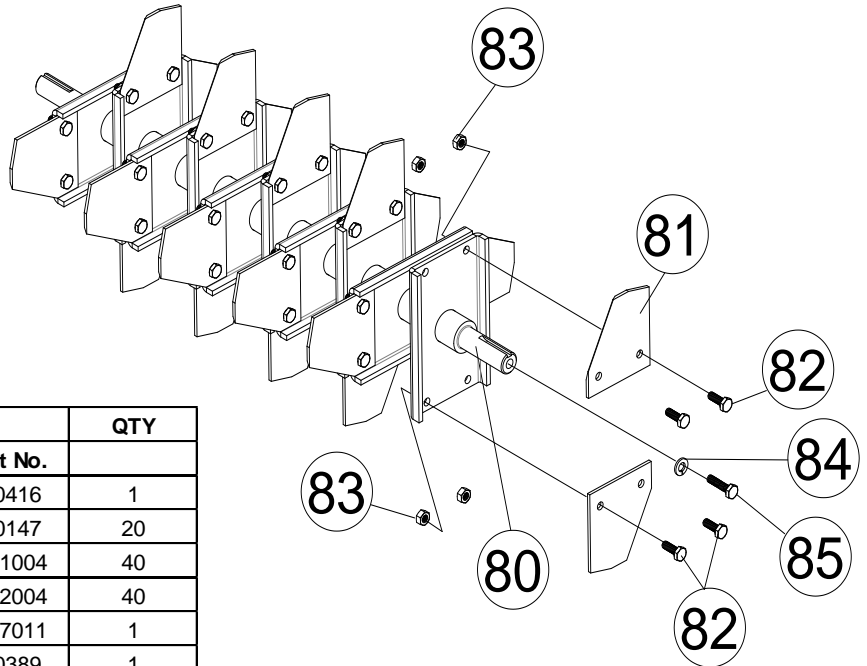

item no.	PARTS LIST	Part No.	QTY
80	SHAFT SLICING WA	350416	1
81	BLADE SLICING WA	350147	20
82	SCREWCAP 1/4"-20 X 3/4	8041004	40
83	NUT LOCK 1/4" - 20 2 WAY	8142004	40
84	WASHER LOCK 5/16" S/T MED	8177011	1
85	SCREWCAP 5/16"- 24 X 1 1/4" GR 8 ZP	400389	1

SPRING TINE REEL ASSY - 350355-S

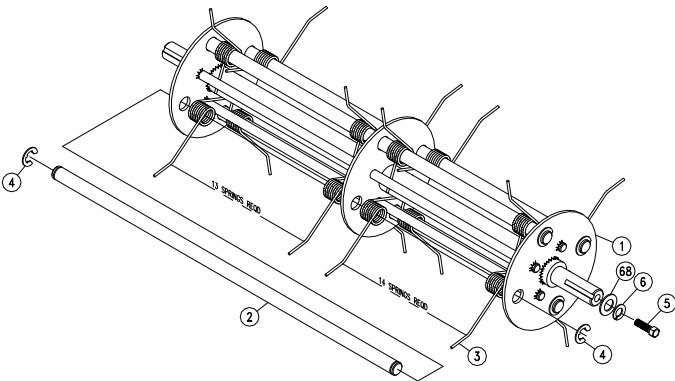

item no.	PARTS LIST	Part No.	QTY
1	SHAFT WA SPRING TINE REEL	350353	1
2	SHAFT SPRING TINE REEL	350351	4
3	SPRING TINE	350352	108
4	RING RETAINING 1/2"	350146	8
5	SCREWCAP 3/8"-16 X 1" HCS ZP	8041050	1
6	WASHER LOCK 3/8 S/T MED	8177012	1
68	WASHER 3/8 FLAT CUT	8171004	1

SPRING REPLACEMENT KIT - 350356-S

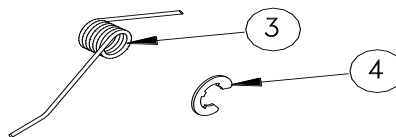

item no.	PARTS LIST	Part No.	QTY
3	SPRING TINE	350352	108
4	RING RETAINING 1/2"	350146	8



PARTS DRAWING

PR550, PR550H, OS552,
OS552H,

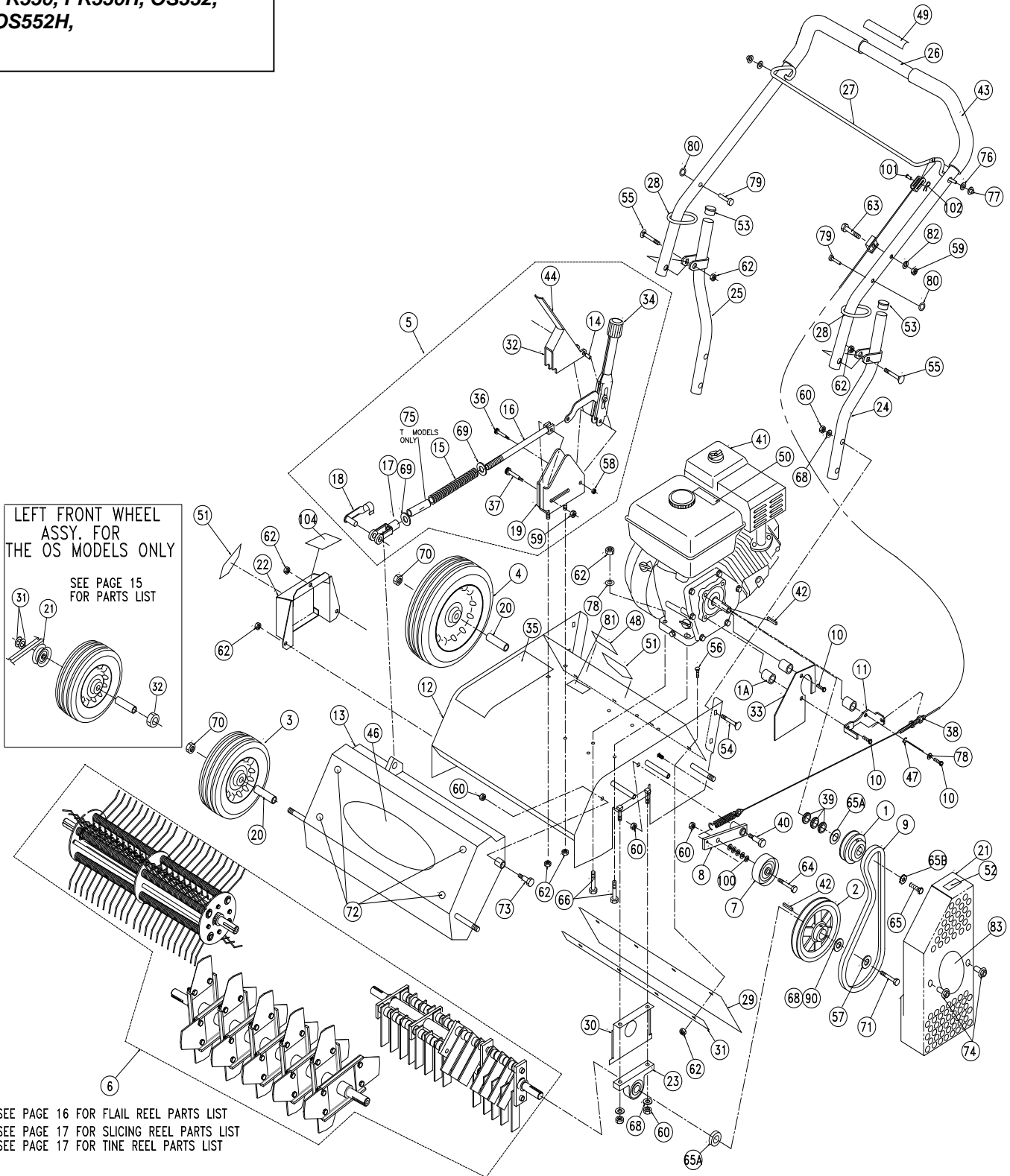



PARTS LIST

item no.	PARTS LIST	PR550 Part No.	QTY	PR550H Part No.	QTY	OS552 Part No.	QTY	OS552H Part No.	QTY
1	Pulley 3" OD	350101	1	350101	1	350101	1	350101	1
1A	Spacer 5/8 OD X 3/8 ID X 1.0 LG	350401	3	350401	3	350401	3	350401	3
2	Pulley 6.5" OD X 3/4"	350102	1	350102	1	350102	1	350102	1
3	WHEEL 8.0" X 5/8" BEARING	350103	2	350103	2	350103	2	350103	2
4	WHEEL 10.0" X 5/8" BEARING	350104	2	350104	2	350104	2	350104	2
5	Height Adjust Assy	350107	1	350107	1	350107	1	350107	1
6	Reel Flail / Slicing / Spring Assy	350112	1	350112	1	350414	1	350414	1
7	Pulley Idler 2.75"	350114	1	350114	1	350114	1	350114	1
8	Arm Idler WA	350115	1	350115	1	350115	1	350115	1
9	Belt 5L X 36	350116	1	350116	1	350116	1	350116	1
10	Screwcap 5/16" x 24 x 1 1/2 Gr5 HCS	8042030	3	8042030	3	8042030	3	8042030	3
11	Bracket Mount Clutch Cable	350119	1	350119	1	350119	1	350119	1
12	Chassis WA W/ Label	350194	1	350194	1	350194	1	350194	1
13	Frame Front WA	350121	1	350121	1	350121	1	350121	1
14	Bushing 0.375 OD X 0.256 ID X 0.88	350309	1	350309	1	350309	1	350309	1
15	Spring Height Adjust PR500	350125	1	350125	1	350125	1	350125	1
16	Link Height Adjust PR500	350126	1	350126	1	350126	1	350126	1
17	Yoke 1/2 - 20	350127	1	350127	1	350127	1	350127	1
18	Pin Yoke 1/2"	350128	1	350128	1	350128	1	350128	1
19	Bracket Mount Hgt. Adj. WA	350182	1	350182	1	350182	1	350182	1
20	Spacer Spanner Wheel PR500	350130	4	350130	4	350130	4	350130	4
21	Guard Belt WA W/ Label	350384	1	350384	1	350384	1	350384	1
22	Guard Shaft WA W/ Label	350196	1	350196	1	350196	1	350196	1
23	Bearing 3/4" Cast Pillow Block	350133	2	350133	2	350133	2	350133	2
24	Handle Lower LH WA	350134	1	350134	1	350134	1	350134	1
25	Handle Lower RH WA	350135	1	350135	1	350135	1	350135	1
26	Handle Upper PR500	350375	1	350375	1	350375	1	350375	1
27	Bail Clutch WA	350374	1	350374	1	350374	1	350374	1
28	Loop Folding Handle	350138	2	350138	2	350138	2	350138	2
29	Deflector Rubber	350167	1	350167	1	350167	1	350167	1
30	Shield Bearing	350168	2	350168	2	350168	2	350168	2
31	Bar Clamp Deflector	350171	1	350171	1	350171	1	350171	1
32	Bracket Height Adjust Lock WA	350173	1	350173	1	350173	1	350173	1
33	Guard Pulley Back	350400	1	350400	1	350400	1	350400	1
34	Lever Height Control	350175	1	350175	1	350175	1	350175	1
35	Label Instr. Hgt. Adj.	350176	1	350176	1	350176	1	350176	1
36	Bolt Shoulder 1/4" x 1 3/4"	350178	1	350178	1	350178	1	350178	1
37	Bolt Shoulder 5/16" x 1 3/4"	350179	1	350179	1	350179	1	350179	1
38	Cable Clutch PR	350408-S	1	350408-S	1	350408-S	1	350408-S	1
39	Bushing Caster Yoke Spacer	520034	3	520034	3	520034	3	520034	3
40	BOLT SHOULDER 1/2" X 1"	500114	1	500114	1	500114	1	500114	1
41	ENGINE HONDA 5.5 H.P. GX160	-	-	600115	1	-	-	600115	1
	ENGINE 5.5 HP B&S VANGUARD	350379	1	-	-	350379	1	-	-
42	KEY 3/16" X 1"	9201078	2	9201078	2	9201078	2	9201078	2
43	GRIP 1" x 13"	400570	2	400570	2	400570	2	400570	2
44	GRIP LEVER 1/8 x 1 x 5"	500181	1	500181	1	500181	1	500181	1
45	LABEL INSTRUCTION SEEDER BOX	-	-	-	-	350288	1	350288	1
46	LABEL PRODUCT DECAL OVAL	350193	1	350193	1	350193	1	350193	1
47	FINGER BELT WIRE	350301	1	350301	1	350301	1	350301	1
48	LABEL DANGER THROWN OBJECT	810736	1	810736	1	810736	1	810736	1
49	LABEL CLUTCH VQ	830503	1	830503	1	830503	1	830503	1
50	LABEL WARNING FUEL EN/SP	100261	1	-	-	100261	1	-	-
51	LABEL WARNING	400424	2	400424	2	400424	2	400424	2
52	LABEL DANGER GUARD	900327	1	900327	1	900327	1	900327	1
53	PLUG CAP 1" RD	890132	2	890132	2	890132	2	890132	2
54	BOLT CARRAIGE 3/8-16 x 1 3/4	8024061	4	8024061	4	8024061	4	8024061	4
55	BOLT CARRAIGE 5/16-18 x 1 3/4	8024043	2	8024043	2	8024043	2	8024043	2
56	BOLT CARRIAGE 5/16 -18 x 3/4	8024039	4	8024039	4	8024039	5	8024039	5
57	WASHER LOCK 3/8" S/T MED	8177012	1	8177012	1	-	-	-	-
	WASHER LOCK 5/16" TW TOOTH	-	-	-	-	430298	1	430298	1
58	NUT LOCK #10-24	8164005	1	8164005	1	8164005	1	8164005	1
59	NUT LOCK 1/4-20	8160001	2	8160001	2	8160001	5	8160001	5
60	NUT LOCK 3/8-16	8160003	12	8160003	12	8160003	12	8160003	12
61									
62	NUT LOCK 5/16-18	8160002	15	8160002	15	8160002	16	8160002	16
63	SCREWCAP 1/4-20 x 1 1/2	8041008	1	8041008	1	8041008	1	8041008	1
64	SCREWCAP 3/8 - 16 x 1 3/4	8041053	1	8041053	1	8041053	1	8041053	1



PR & OS Owner's Manual

item no.	PARTS LIST	PR550 Part No.	QTY	PR550H Part No.	QTY	OS552 Part No.	QTY	OS552H Part No.	QTY
65	SCREWCAP 5/16-24 x 3/4" GR.5	8042026	1	8042026	1	8042026	1	8042026	1
65A	Washer 3/4 SAE	8172015	2	8172015	2	8172015	2	8172015	2
65B	Washer 5/16 Twist Tooth	430298	1	430298	1	430298	1	430298	1
66	SCREWCAP 5/16 - 18 x 1 1/2	8041030	4	8041030	4	8041030	4	8041030	4
68	WASHER 3/8 FLAT CUT	8171004	9	8171004	9	8171004	8	8171004	8
69	WASHER 1/2 SAE ZP	8172011	2	8172011	2	8172011	5	8172011	5
70	NUT LOCK 1/2" - 13 THIN HGT	8161044	4	8161044	4	8161044	4	8161044	4
71	SCREWCAP 3/8" - 16 X1" HCS ZP	8041050	1	8041050	1	8041050	1	8041050	1
72	BUTTON SOCKET 5/16-18X5/8"	350266	4	350266	4	-	-	-	-
73	BOLT SHOULDER 1/2" x 2"	520031	2	520031	2	520031	2	520031	2
74	FLANGE SCREW 0.375 -16 X 0.75	791080	2	791080	2	791080	2	791080	2
76	WASHER 3/8 SAE	8172009	2	8172009	2	8172009	2	8172009	2
77	NUT PAL 3/8	360218	2	360218	2	360218	2	360218	2
78	WASHER 1/4 FLAT CUT	8171002	5	8171002	5	8171002	5	8171002	5
79	PIN CLEVIS 3/8" X 1.625	520119	2	520119	2	520119	2	520119	2
80	RETAINER 3/8" BOLT PUSH NUT	360279	2	360279	2	360279	2	360279	2
81	LABEL SPARK ARRESTOR EN/SP	-	-	100256	1	-	-	100256	1
82	WASHER 1/4 SAE	8172007	1	8172007	1	8172007	1	8172007	1
83	LABEL LOGO PRODUCT SM CIRCLE	890456	1	890456	1	890456	1	890456	1
90	WASHER 1.125" OD X .344 ID X .25 THK	-	-	-	-	441150	1	441150	1
100	WASHER FLAT 5/16"	8171003	5	8171003	5	8171003	5	8171003	5
101	SCREW MACH #10-24 X 5/8" HWF ZP	8059135	1	8059135	1	8059135	1	8059135	1
102	NUT LOCK #10-24 HEX	8164005	1	8164005	1	8164005	1	8164005	1
104	LABEL MADE IN U.S.A.	520116	1	520116	1	520116	1	520116	1

